

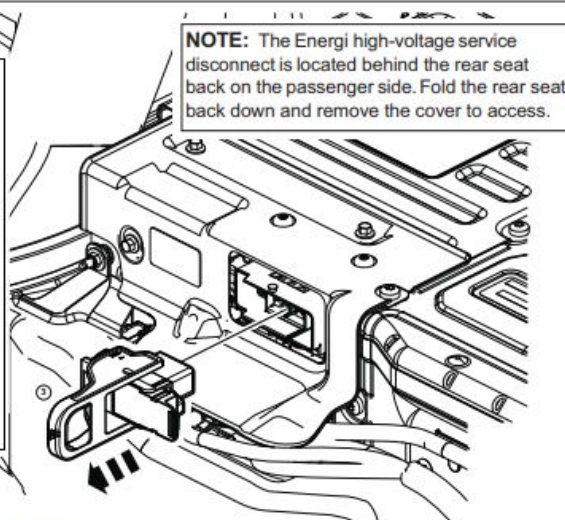

BESTHYBRID BATTERIES

2013 - 2018 Ford C-Max Hybrid and Energi Battery Removal and Installation Instructions

Step 1: Remove Orange HV Disconnect Plug

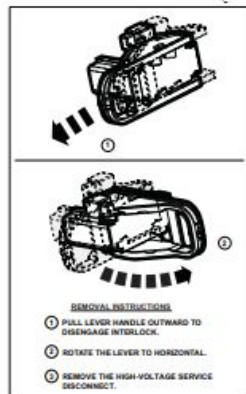
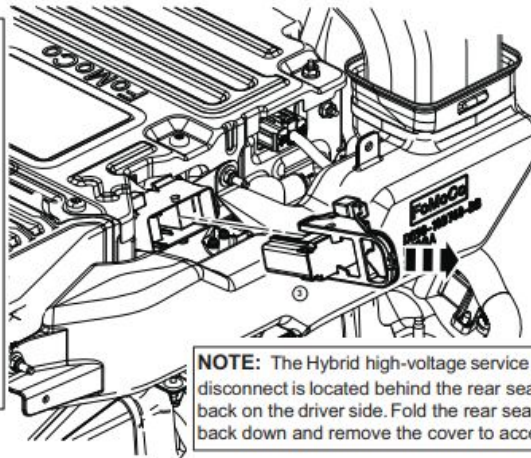
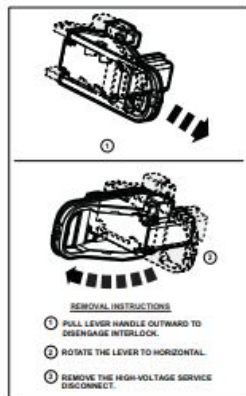

3. Remove the cargo cover.



4. Remove the 12V battery cover.

5. Disconnect and isolate the 12V negative battery cable.

6. Remove the rear cargo trim.

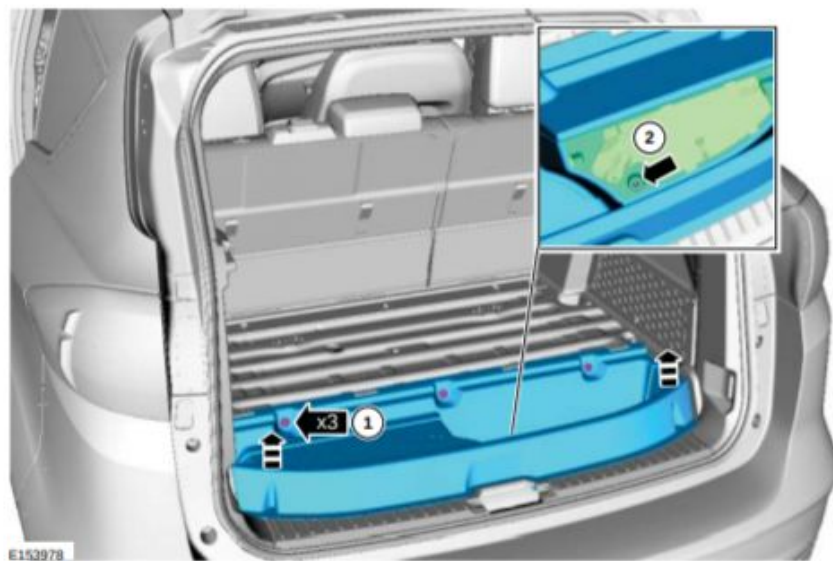

7. Remove the 12V battery cover.

8. Disconnect and isolate the 12V negative battery cable.

9. Remove the rear cargo trim.

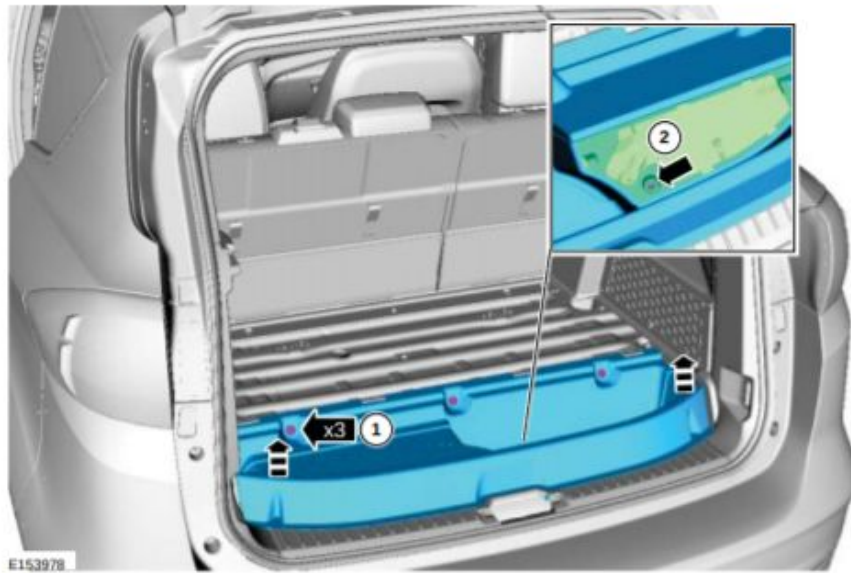

10. Remove the rear trunk scuff.

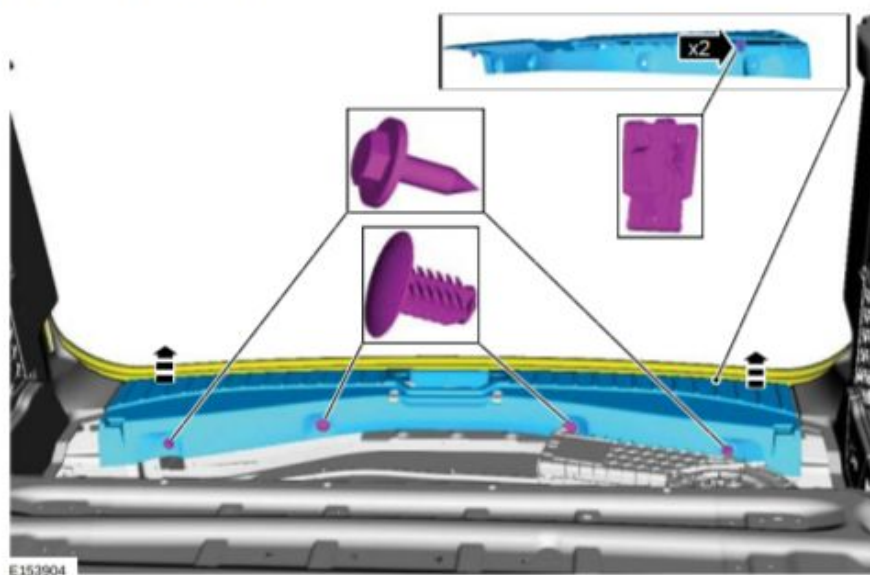

11. Remove the LH rear door scuff.

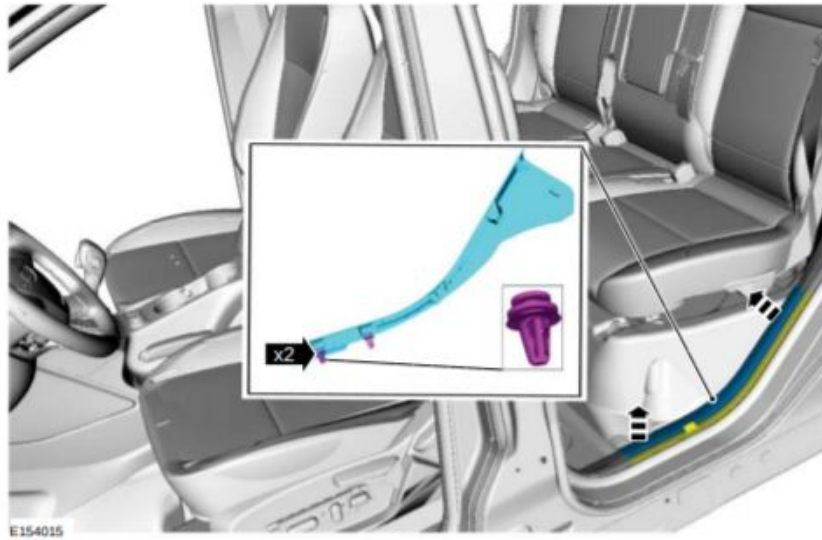

12. Remove the RH rear door scuff.

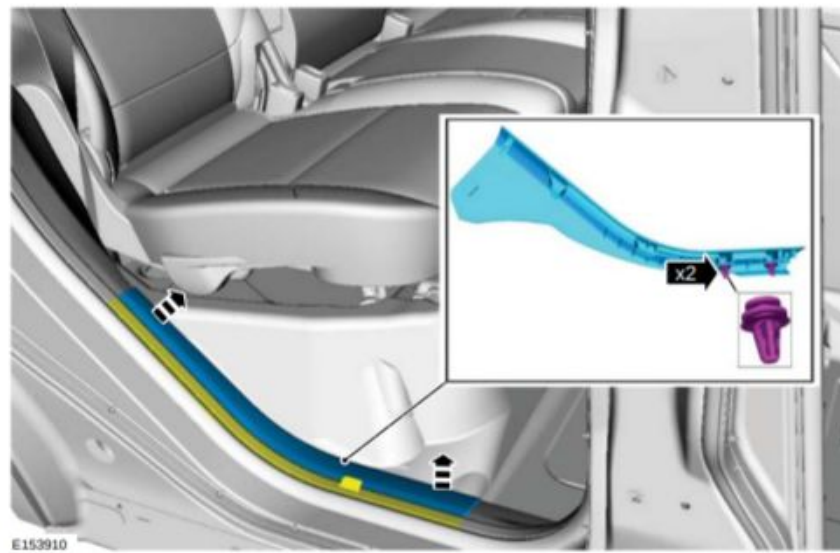

13. Disengage and position the LH loadfloor trim panel slightly away.

14. Disconnect the trim panel appropriately and remove.

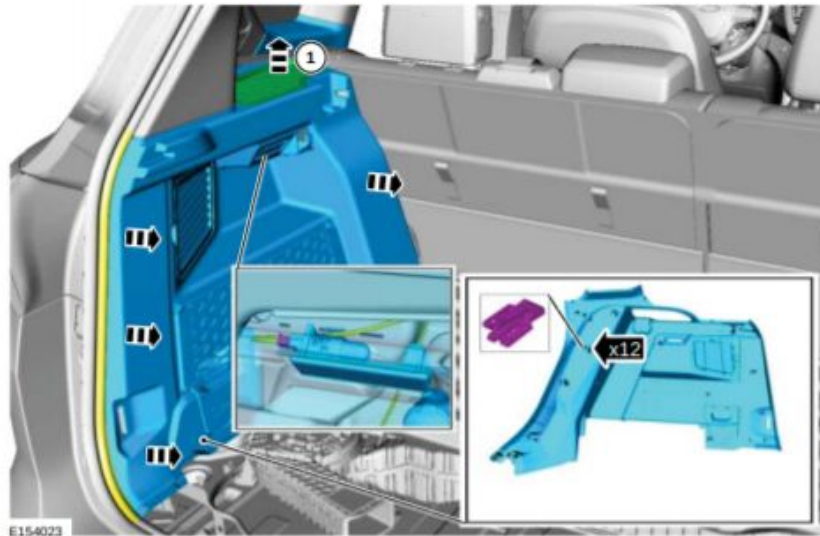

15. Disengage and position the RH loadfloor trim panel slightly away.

16. Disconnect the trim panel appropriately and remove.

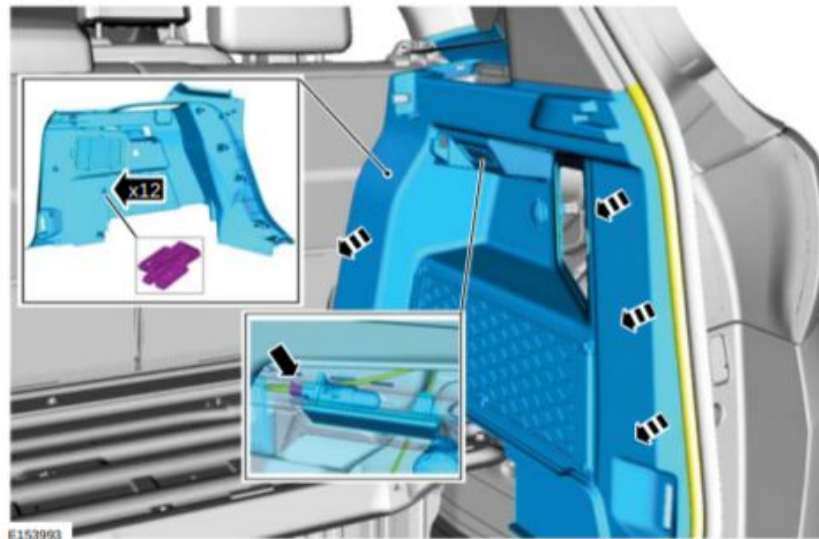

17. Fold the rear seat back down.

18. Remove the upper high-voltage battery inlet ducts.

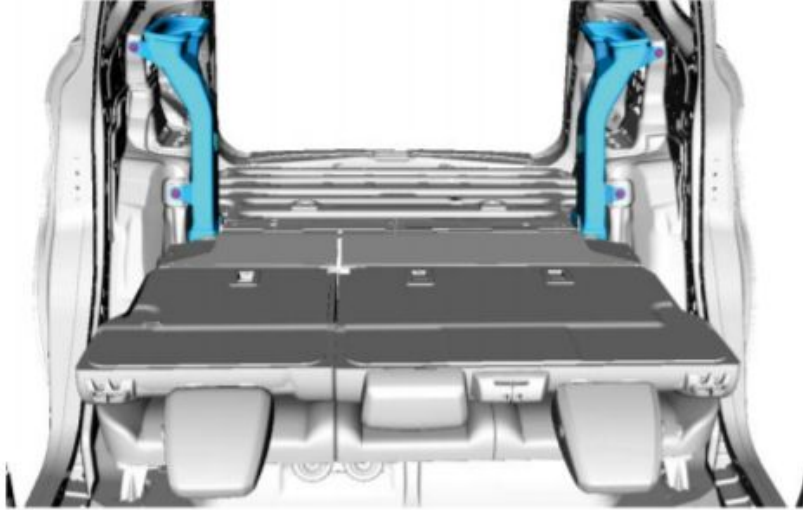

19. Remove the gap hider from the rear seat back.

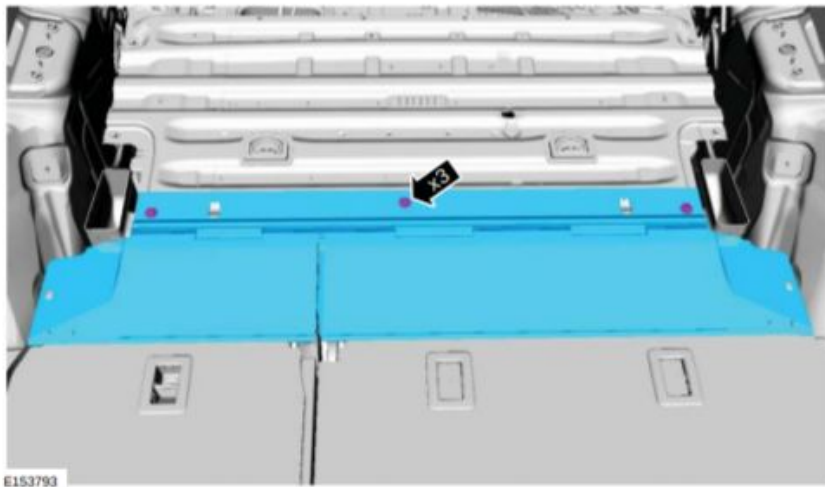

E153793

20. Remove the top cover from the High-Voltage Battery.

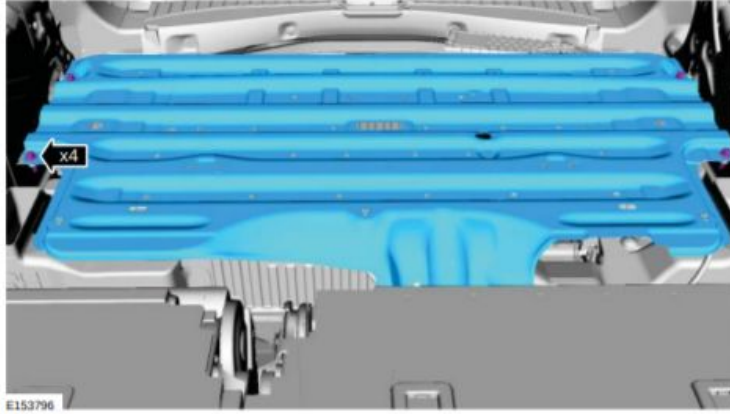

21. Return the rear seat back to the upright position.

22. Remove the rear seat cushions.

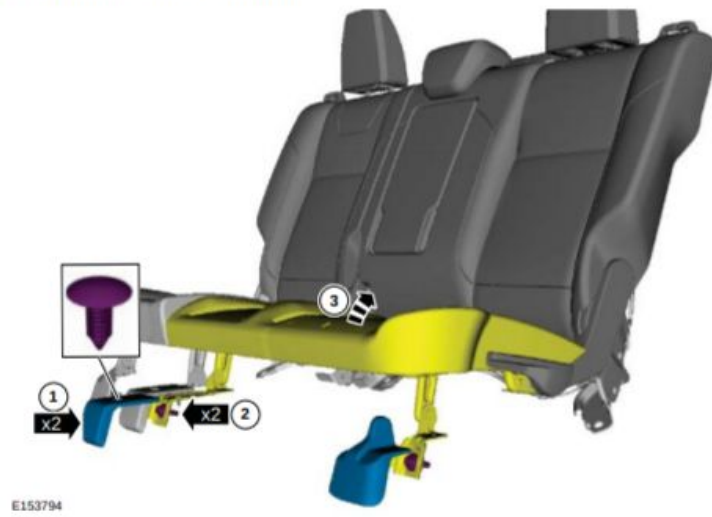

23. Remove the rear seat backs.



24. Disconnect the high-voltage battery wiring.

25. Remove the lower high-voltage battery air inlet ducts.

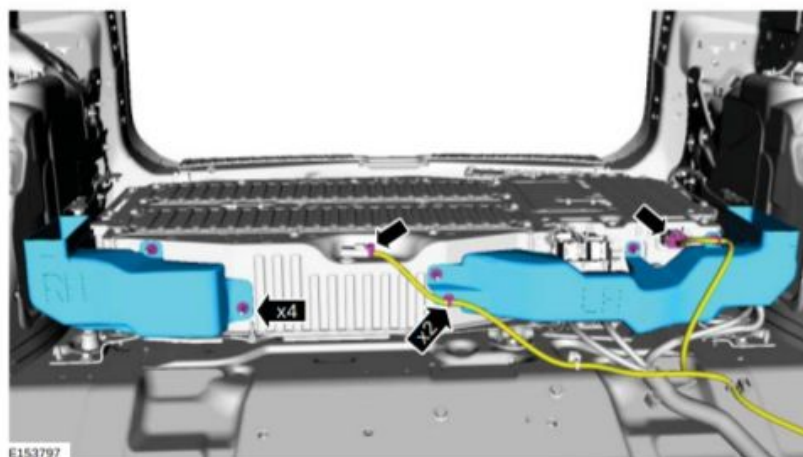

26. Remove the high-voltage battery wiring cover.

27. Disconnect the high-voltage battery ground harness.

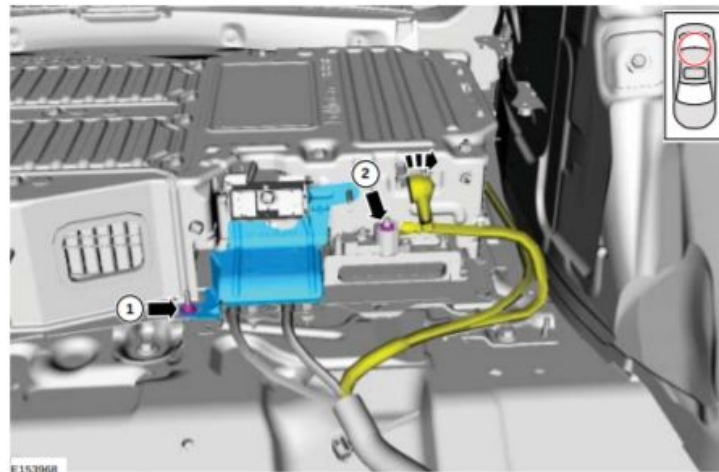

28. Disconnect the high-voltage battery wiring.

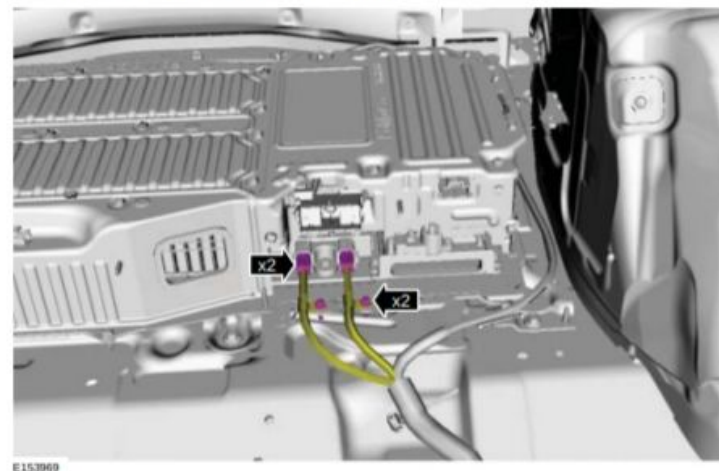

29. Disconnect the 12V battery harness.

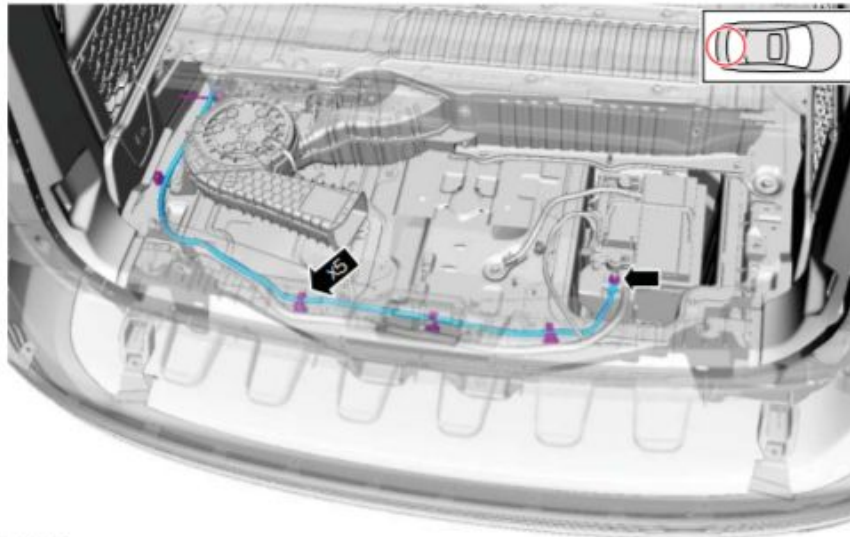

E153200

30. Disconnect the wiring from the high-voltage battery cooling fan.

31. Remove the high-voltage battery cooling fan and air outlet duct.

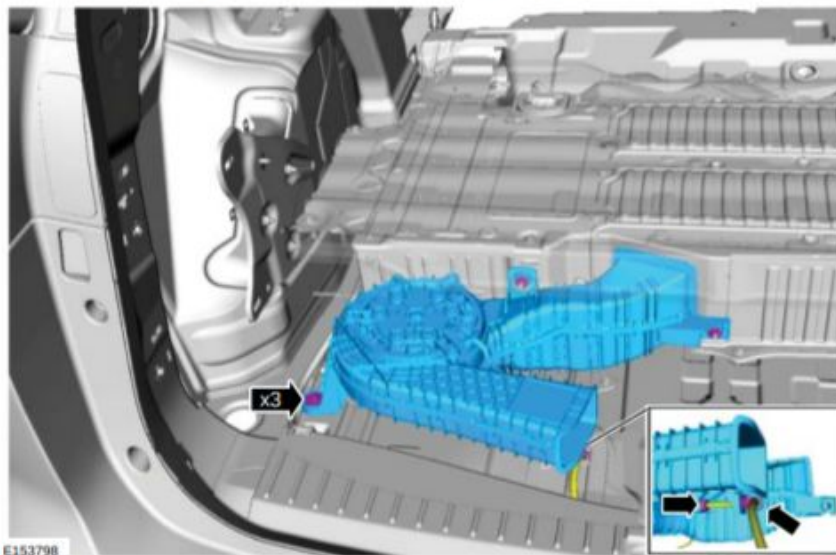

E153798

32. Remove the fasteners securing the high-voltage battery.

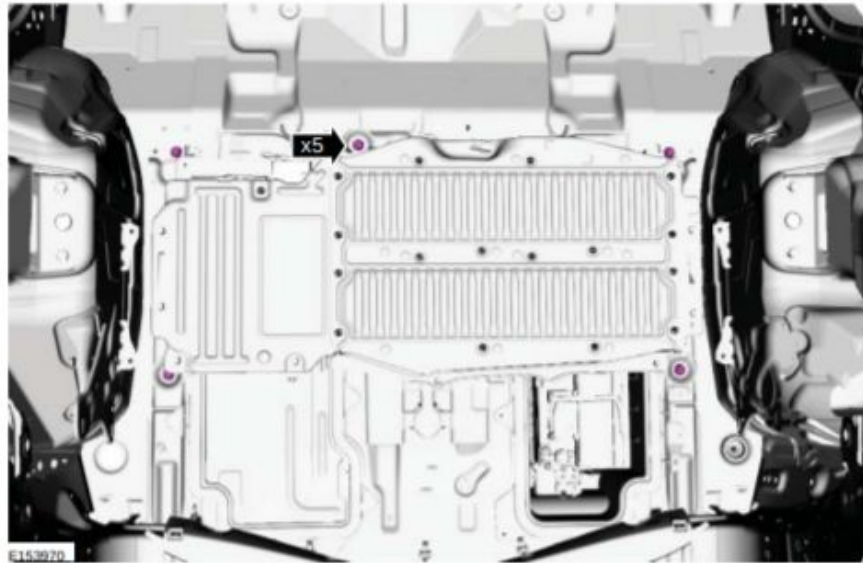

33. With the help of an assistant, remove the high-voltage battery through the rear of the vehicle.

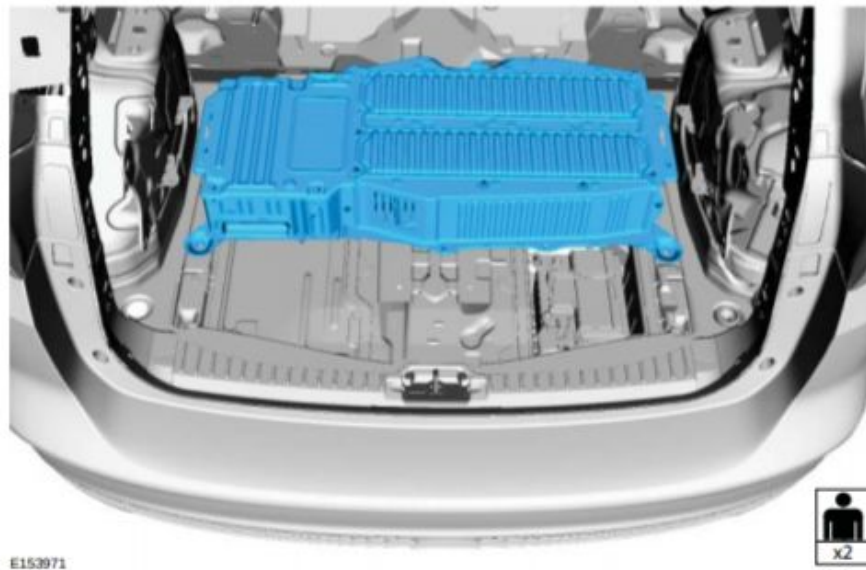

For installation please follow the same steps in reverse order.